

Horizontal/Fill/Seal Machine

POSI-Placement Infeed



Features:

- Random to timed product feed to Hayssen RT wrapper
- Servo drive technology
- All stainless steel construction
- Product positively placed onto film
- Can be fully integrated to HayssenSandiacre RT 2000 or independently interfaced to existing RT machines and 3rd party wrappers

Barry-Wehmiller

Horizontal/Fill/Seal Machine

POSI-Placement Infeed

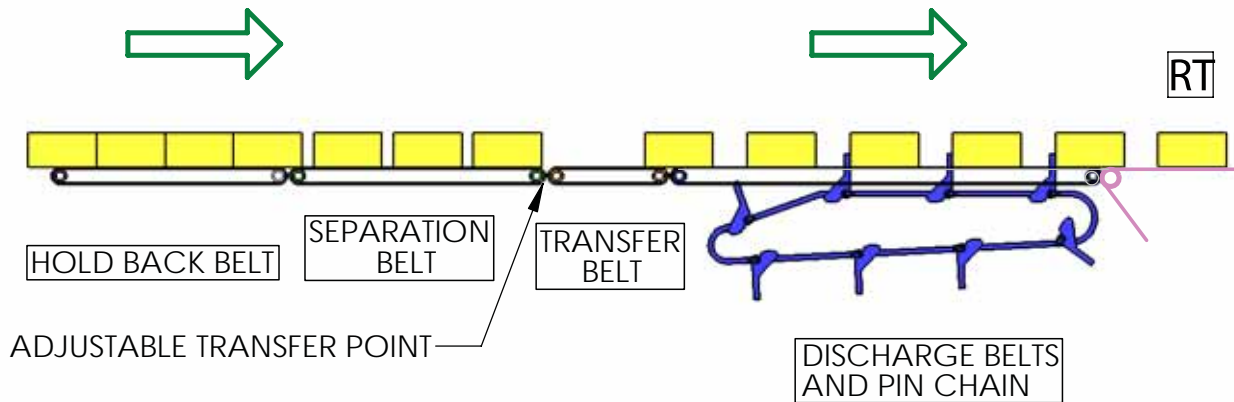

The Posi-Placement infeed conveyor requires little upstream product accumulation. This accumulation can account for some significant product flow gaps and surges. However, the more product accumulation available, the more inconsistency of product flow the Posi-Placement can manage reliably.

A series of photo eyes mounted over the product accumulation are used to monitor the amount of stored product. Based on the amount of product present, the RT and Posi-Placement will increase or decrease speed as needed in order to keep the system running. There are multiple degrees of flexibility in manipulating the product flow to the Posi-Placement and wrapper combination.

The Posi-Placement accepts the product, head to tail, from an accumulation conveyor. It draws a gap between the products based on package length. At this point, chain pins positively place the product onto the RT wrapper.

Power Requirements:

230 vac, single phase, 50 or 60 hz,
30 amp service

Air Requirements:

80 psi (negligible consumption)

Production Rate:

Up to 250 per minute
(subject to product and packaging material evaluation)

Package Range:

Minimum	Width:	1.75" (44.5 mm)
	Length:	2" (50 mm)
	Height:	0.25" (6.5 mm)
Maximum	Width:	4.25" (108 mm)
	Length:	12" (305 mm)
	Height:	2.5" (65 mm)

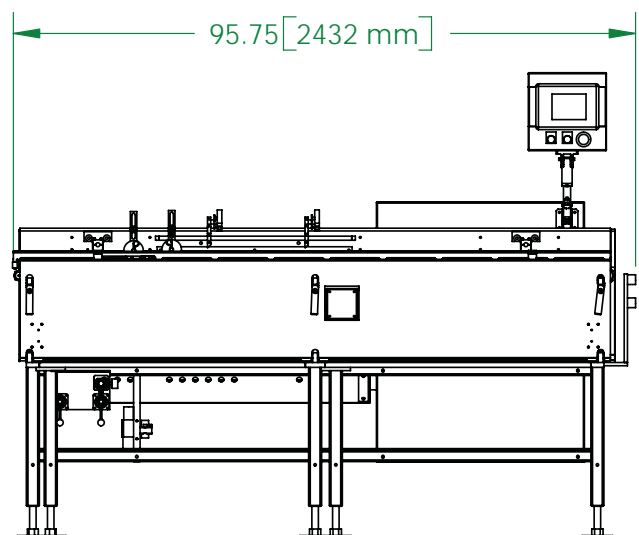

(Dimensions shown are approximate and subject to change; consult factory for exact figures)

HayssenSandiacre

USA - 225 Spartangreen Boulevard • Duncan, SC 29334 USA • 864/486-4000

UNITED KINGDOM - 16 Roman Way • Thetford, Norfolk IP24 1XB United Kingdom • + 44 (0) 1842 754171

UNITED KINGDOM - 101 Lilac Grove • Beeston, Nottingham, NG9 1PF • United Kingdom • +44 (0) 115 967 8787

MEXICO - Castorena 324-118 • Cuajimalpa • 05000 México, D.F • +(52-55)5813-7770

www.hayssensandiacre.com • sales@hayssensandiacre.com